



FOOD EQUIPMENT

SERVING THE FOOD INDUSTRY SINCE 1951

**30-INCH STAINLESS STEEL ELECTRIC OPEN WELL
HOT FOOD TABLE WITH 2 PANS CAPACITY, CUTTING
BOARD AND UNDERSHELF**

Item: 46646 Model: FW-CN-0002-H

**KEEP YOUR HOT FOODS
READILY AVAILABLE AT
SAFE TEMPERATURE**

Perfect for buffet and catering services, Omcan's 30inch Stainless Steel Electric Open Well Hot Food Table with Cutting Board and Undershef is designed to keep your hot foods readily available at safe temperature. With a durable stainless steel construction, this food warmer has a convenient undershef where you could store extra serving utensils, food pans, or any other kitchen tools that you need, as well as a polycarbonate cutting board as an extra work space in case you need to fill out food pans or plates.



Pans not included.



WARRANTY
PARTS AND LABOR



SHIPPED ON PALLET



Authorized Dealer

TECHNICAL SPECIFICATIONS

| | |
|------------------------|---------------------------------------|
| ITEM NUMBER | 46646 |
| MODEL | FW-CN-0002-H |
| MAX. TEMPERATURE | Approximately 212°F / 100°C |
| POWER | 2000W |
| ELECTRICAL | 240V / 60Hz / 1Ph |
| AMPS | 8.33 |
| MATERIAL | Stainless Steel |
| CUTTING BOARD MATERIAL | Polyethylene |
| NUMBER OF PANS | 2 (Pans not included) |
| PAN SIZE | 20.78" x 12.8" x 6" (full size) |
| UNDERSHELF SIZE | 27.6" x 18" x 2" 702 x 462 x 50 mm |
| CUTTING BOARD SIZE | 30" x 7.9" x 0.5" 763 x 200 x 12 mm |
| DIMENSIONS (WDH) | 30" x 30" x 34" 763 x 772 x 870 mm |
| GROSS DIMENSIONS | 34" x 25" x 20" 860 x 640 x 520 mm |
| WEIGHT | 34kg. 75lbs. |
| GROSS WEIGHT | 46kgs. 101lbs. |

FEATURES

- Stainless steel structure with individual control
- Adjustable stainless steel undershelf and removable Polyethylene cutting board
- Adjustable stainless steel feet
- Stainless steel heating element
- 2 independent infinite controls
- Pans not included

OPTIONAL ACCESSORIES

- Full Size Pan (Item 80258)
- Spillage Pan (Item 80907)

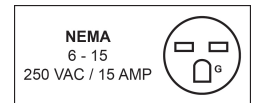

TECHNICAL DRAWINGS AND DIMENSIONS

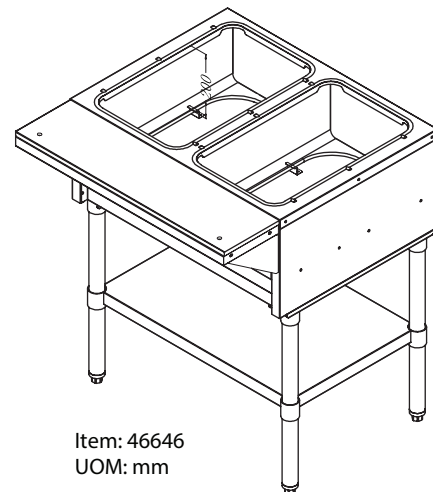
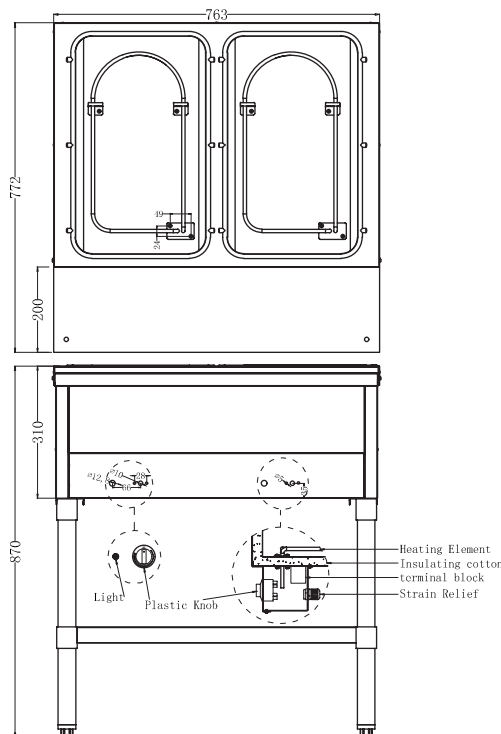

Item: 46646
UOM: mm

OMCAN INC.

Telephone: 1-800-465-0234
 Fax: (905) 607-0234
 Email: sales@omcan.com
 Website: www.omcan.com



Follow us to keep up to date with the latest news and offers

